

User Guide



5.8 GHz Amplified Cordless
Speakerphone/Answering Machine
With Caller ID & Call Waiting
(Supports up to 3 additional handsets)

C4230™



E
N
G
L
I
S
H

E
S
P
A
Ñ
O
L

F
R
A
N
C
A
I
S

TABLE OF CONTENTS

Getting Started

Safety Instruction	4
Parts Checklist.....	7
Quick Reference Guide	8

Installation.....

Telephone Operation.....

Basic Handset Operation	14
Basic Base Operation	18
Other Features on Handset.....	21
Date and Time	23

Initial Setup.....

Phonebook	26
Caller ID	30
Telephone Answering Machine	33
Access from handset	35
Access from a Remote Location	40

Troubleshooting

Technical Specifications

FCC Requirements and Regulations.....

Warranty and Service

Introduction

Thank you for purchasing the C4230, 5.8 GHz amplified cordless phone, from Clarity. Using our patented Digital Clarity Power, the C4230 clearly amplifies incoming sound up to 50 dB while cutting out background noise. This phone has many features including a digital answering machine and speakerphone.

This User Guide and Quick Start Guide will provide you with the information you need to use your C4230 effectively, easily and safely. Read this manual thoroughly before using this telephone. Keep the manual near the phone for easy reference.

SAFETY INSTRUCTIONS

When using your telephone equipment, basic safety precautions should always be followed to reduce the risk of fire, electric shock and injury to persons including the following:

1. Read and understand all instructions.
2. Follow all warnings and instructions marked on the telephone.
3. Do not use this telephone near a bath tub, wash basin, kitchen sink or laundry tub, in a wet basement, near a swimming pool or anywhere else there is water.
4. Avoid using a telephone (other than a cordless type) during a storm. There may be a remote risk of electrical shock from lightning.
5. Do not use the telephone to report a gas leak in the vicinity of the leak.
6. Unplug this telephone from the wall outlets before cleaning. Do not use liquid cleaners or aerosol cleaners on the telephone. Use a damp cloth for cleaning.
7. Place this telephone on a stable surface. Serious damage and/or injury may result if the telephone falls.
8. Do not cover the slots and openings on this telephone. This telephone should never be placed near or over a radiator or heat register. This telephone should not be placed in a built-in installation unless proper ventilation is provided.
9. Operate this telephone using the electrical voltage as stated on the base unit or in the owner's manual. If you are not sure of the voltage in your home, consult your dealer or local power company.
10. Do not place anything on the power cord. Install the telephone where no one will step or trip on the cord.
11. Do not overload wall outlets or extension cords as this can increase the risk of fire or electrical shock.
12. Never push any objects through the slots in the telephone. They can touch dangerous voltage points or short out parts that could result in a risk of fire or electrical shock. Never spill liquid of any kind on the telephone.
13. To reduce the risk of electrical shock, do not take this phone apart. Opening or removing covers may expose you to dangerous voltages or other risks. Incorrect reassembly can cause electric shock when the appliance is subsequently used.
14. Unplug this product from the wall outlet and refer servicing to the manufacturer under the following conditions:
 - A. When the power supply cord or plug is frayed or damaged.
 - B. If liquid has been spilled into the product.
 - C. If the telephone has been exposed to rain or water.
 - D. If the telephone does not operate normally by following the operating instructions. Adjust only those controls that are covered by the operating instructions. Improper adjustment may require extensive

SAVE THESE INSTRUCTIONS

SAFETY INSTRUCTIONS

work by a qualified technician to restore the telephone to normal operation.

- E. If the telephone has been dropped or the case has been damaged.
 - F. If the telephone exhibits a distinct change in performance.
15. Never install telephone wiring during a lightning storm.
 16. Never install telephone jacks in wet locations unless the jack is specifically designed for wet locations.
 17. Never touch uninsulated telephone wires or terminals unless the telephone line has been disconnected at the network interface.
 18. Use caution when installing or modifying telephone lines.
 19. Use only the power cord and batteries indicated in the manual. Do not dispose of batteries in a fire. They may explode. Check with local codes for possible special disposal instructions.
 20. Plug the AC adaptor into the outlet that is nearest and most accessible to the telephone.

Exposure to high volume sound levels may damage your hearing. Although there is no single volume setting that is appropriate for everyone, you should always use the handset with the volume set at moderate levels and avoid prolonged exposure to high volume sound levels. The louder the volume, the less time is required before your hearing could be affected. If you experience hearing discomfort, you should stop

using the handset. To protect your hearing, some hearing experts suggest that you:

1. Set the volume control in a low position and then adjust the volume to a comfortable level.
2. Limit the amount of time you use the handset at high volume.
3. Avoid turning up the volume to block out noisy surroundings.

CHILDREN: Never allow children to play with the product – small parts may be a choking hazard and the amplified volume may cause hearing damage.

SAFETY INSTRUCTIONS FOR BATTERIES

Caution: Risk of explosion if battery is replaced by an incorrect type. Dispose of used batteries according to the instructions.

1. Use only the approved battery pack in the handset of your cordless phone.

For Handset Unit:

3.6V 800mAh Ni-MH AAA

GPI International Ltd.:

GP80AAA3BXZ

For Base Unit:

Four (4) AA alkaline batteries

2. Do not dispose of the battery in a fire as it may explode. Check with local codes for possible special disposal instructions.
3. Do not open or mutilate the battery. Released electrolyte is corrosive and may cause damage to the eyes and skin. It may be toxic if swallowed.

SAVE THESE INSTRUCTIONS

SAFETY INSTRUCTIONS

4. Exercise care in handling batteries in order not to short the battery with conducting materials such as rings, bracelets and keys. The battery or conduction material may over-heat and cause burns.
5. Charge the battery (ies) provided with or identified for use with this product only in accordance with the instructions and limitations specified in this manual.
6. Observe proper polarity orientation between the battery pack and the battery charger.

Pacemaker Warning

If you or a member of your household has a pacemaker or other medical devices, consult your physician or the manufacturer of the pacemaker or medical device before using this product. The product should be used in accordance with the guidelines provided by your physician or the manufacturer of the pacemaker or medical device.

CONTENTS & PARTS CHECKLIST

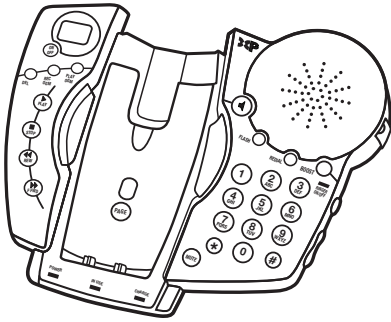

Base



Handset



Battery
compartment cover

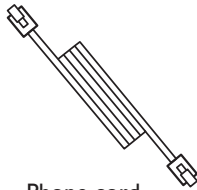

Phone cord

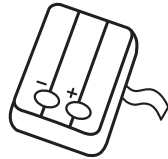

Battery pack

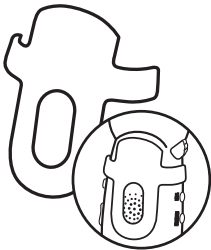

Belt clip

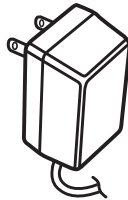

AC power adapter

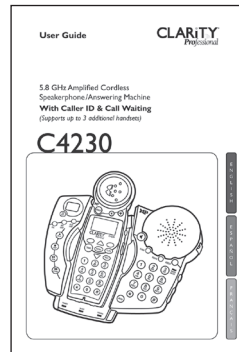

User guide

FUNCTION KEYS

1 Speaker

Press On or Off.

2 Flash

Press to receive an incoming call while on a call. (Call Waiting must be activated)

3 Redial

Press to Redial last number dialed.

4 Boost

Press to add an extra level of amplification over the entire range of volume control.

5 Input for (optional) C2210 Lamp Flasher

6 Ringer Style

Press to adjust the style of ring.

7 Volume

Press to control the outgoing Speaker Volume.

8 Mute button

Press to turn OFF speakerphone microphone.

9 Port for (optional) C2210 Bed Shaker

10 AC Adapter

11 Phone Line Connection

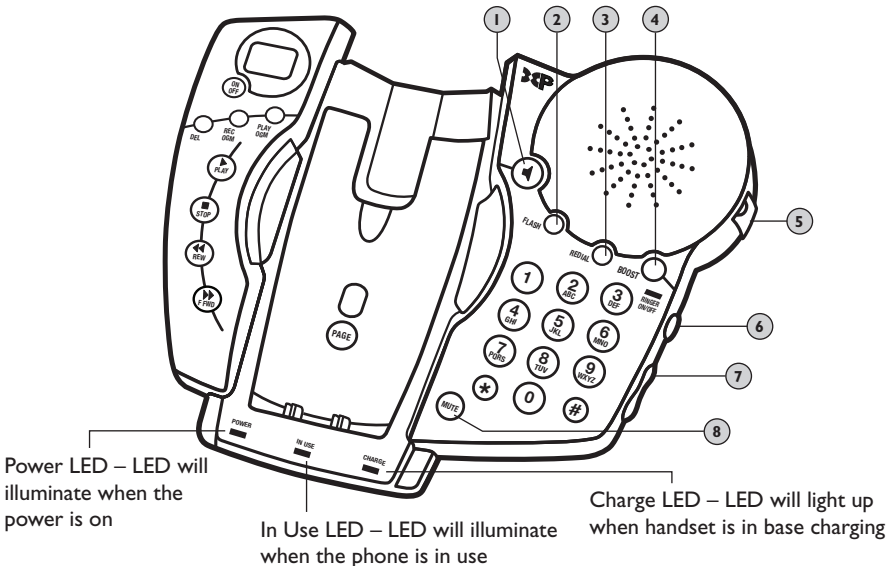
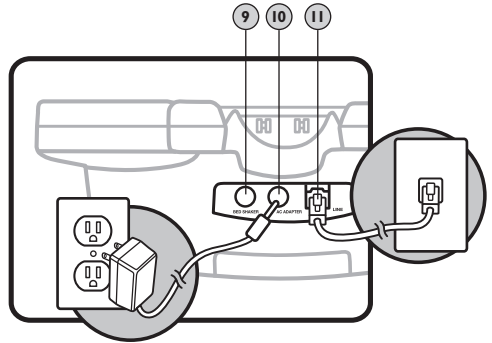

ANSWERING MACHINE DEVICE

- | | |
|--|---|
| <p>12 Answering Machine Display
Displays number of messages.</p> <p>13 On/Off
Press to turn answering machine On or Off.</p> <p>14 OGM/Play
Press to Play outgoing message.</p> <p>15 Delete
Press to Delete a message.</p> <p>16 OGM/REC
Press to Record outgoing message.</p> | <p>17 Play
Press to Play message.</p> <p>18 Stop
Press to STOP message playing.</p> <p>19 Rew
Press to Rewind message.</p> <p>20 FFWD
Press to Fast Forward through the message.</p> <p>21 Page
Press to Page handset.</p> |
|--|---|

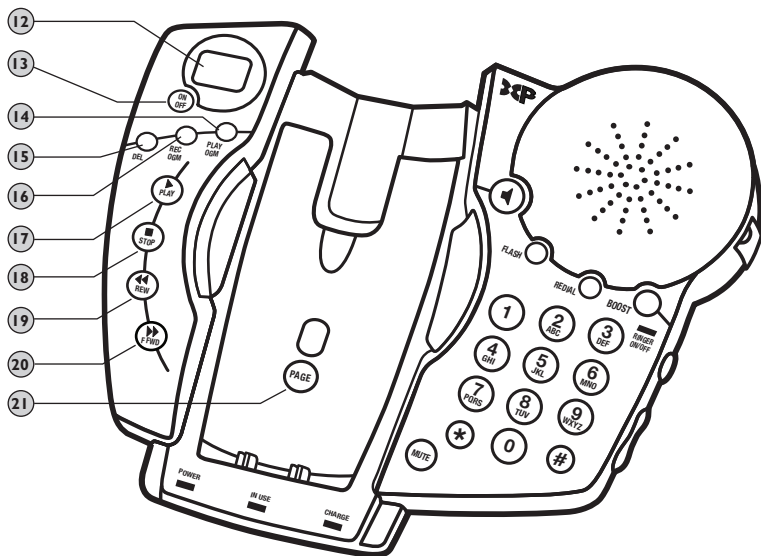

HANDSET

1 Volume Control

The dial controls the volume level of the handset, headset or neckloop, and ringer volumes.

2 Boost

When pressed, an extra level of amplification is added over the entire range of volume.

3 Speaker

Press to activate handset speakerphone. Press again to switch back to earpiece.

4 Soft Keys

Press a soft key to select a menu item displayed just above the key.

5 Arrow Buttons

Press up or down Arrows to navigate through the menus.

6 Talk

To make a call Press the TALK button then dial number.

7 Help Key

Press Help Key button to dial pre-programmed number.

8 Flash/Clear

Flash: Call Waiting service is required. While on a call Press (CL/FL) to receive another incoming call.

Clear: While in the menu Press (CL/FL) to go back to the main menu.

9 Redial/Pause

Press to redial (RD/P) last number dialed or insert Pause (2 seconds) when programming memories or pre-dialing.

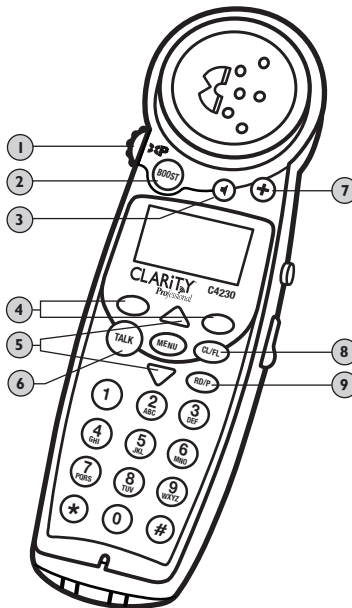

HANDSET

10 Headset

A 2.5 mm headset can be used in the Headset Port.
(We recommend the Plantronics M214C headset.)

11 Tone

Press to select the audio tone for the handset. Boost must be ON to activate tone selection.

12 Intercom

Press to call Base or other handset on system.

13 Ringer ON/OFF

Switch to turn Handset Ringer On.

14 Neck Loop

A 3.5 mm neck loop can be used in the Neck Loop Port.

15 Belt clip

Slide belt clip onto handset as shown.

16 Speaker grill

17 Battery

Insert battery pack such that (+) and (-) on battery touch spring in battery compartment.

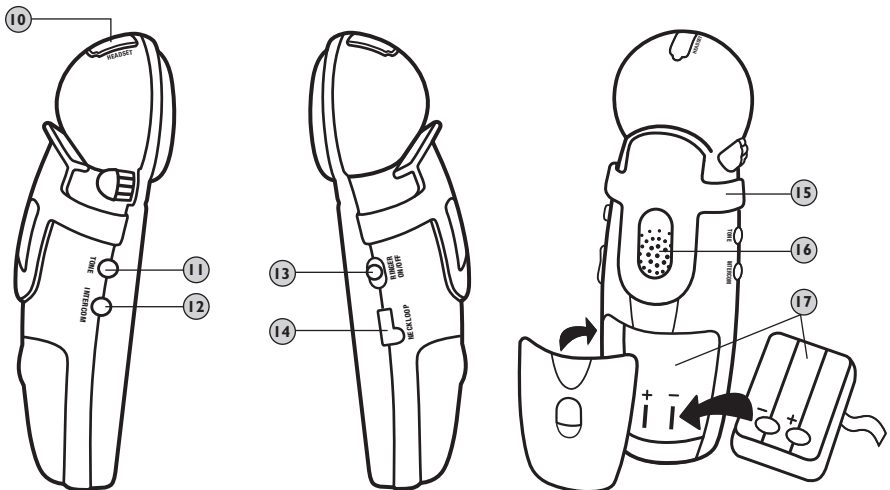

OPTIONAL:

Install belt clip to back of phone as shown.
For hands-free conversations, headset with a 2.5mm plug may be purchased separately.

IMPORTANT:

Circular metal contacts on battery need to touch the metal springs inside battery compartment.

Charging your battery

Battery must be initially charged for a full 12 hours before first use. Failure to fully charge the battery may result in the battery developing a memory. If the battery develops a memory, it will hold less charge with each following charge. Eventually the battery would have to be replaced. **Important:** *You must charge the handset 12 hours before using in order for the handset to register properly to the base.*

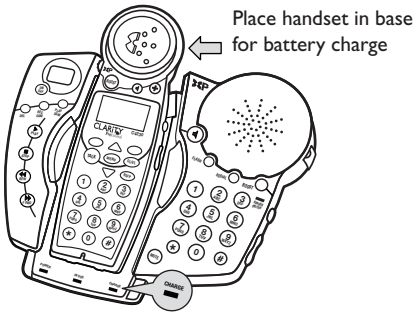

IMPORTANT

Handset battery must charge for 12 hours before using.

Installing the Backup Batteries

If there is a power outage, the C4230 will operate up to four hours with (4) AA Alkaline (non-rechargeable) batteries (not included).

Note: Operation time depends on what features are being used.

To install or replace battery backup batteries

1. Disconnect telephone line cord.
2. Remove batteries from phone.
3. Install four (4) AA Alkaline batteries with negative (-) end of battery touching the spring.

Warning: Disconnect telephone line cord before replacing batteries.

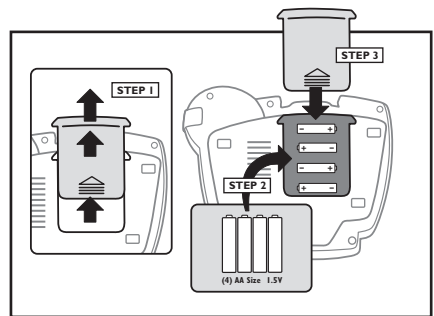

After installing the four (4) AA Alkaline batteries, please refer to the chart below.

Power Supply	Power LED Status
AC adapter and good batteries	Steady Green
AC adapter and no batteries	Steady Red
AC adapter and low batteries	Blinks Green/Red
Power failure and good batteries	Slow flashing Red
Power failure and bad batteries	Fast flashing Red

HOW TO CONNECT YOUR C4230 PHONE

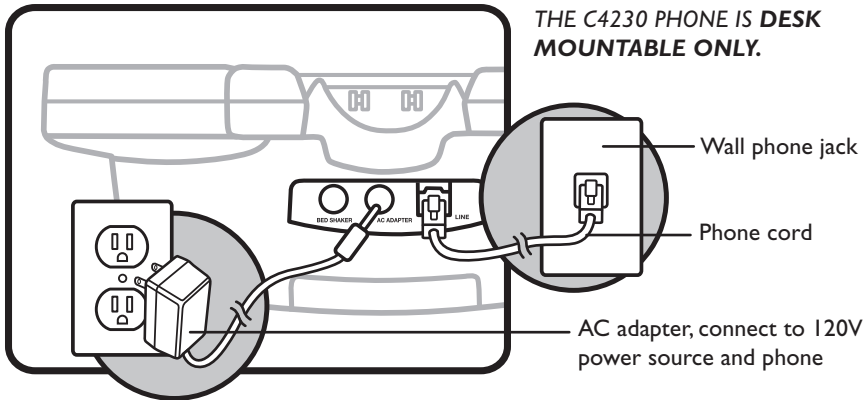

The **phone cord** plugs into the C4230 phone base as shown above. Plug the other end of the **phone cord** into a telephone wall jack.

Connect the **AC adapter** to the back of the base and a 120V wall outlet as shown above.

To avoid potential interference, the phone should not be located near electronic equipment, such as personal computers, televisions or microwave ovens.



HOW TO DIAL OR RECEIVE A CALL

1. Complete connection instructions shown in this guide.
2. Install and **charge battery** as shown on page 11-12.
3. Make sure **Red LED light is on** at bottom of base.

HANDSET

4. To answer a call, press TALK on the handset.
5. When placing a call press TALK and dial number.
6. After completing a call press TALK again and return handset to base unit.

BASE

7. When receiving a call press SPEAKER  button on base.
8. When placing a call press SPEAKER  button then dial number from base.
9. After completing a call press the SPEAKER  button again.
10. Sound will reset to normal level on both handset and base unit after completing calls. Pressing the BOOST button on subsequent calls will return the volume to your set sound level.

TELEPHONE OPERATIONS

BASIC HANDSET OPERATIONS

ANSWERING AND MAKING CALLS

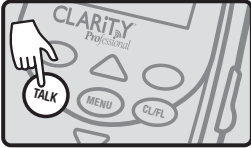

Answering Calls

To answer a call press TALK.

Press FLASH during a call to answer a second call.
(If you have call waiting service)

Making Calls

To make a call, press TALK, then dial number.

To end call, press TALK again, or place handset onto base.

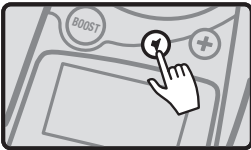

Hands-Free Speakerphone Calls

Press Speaker  to answer incoming calls.

To make an outgoing call, press Speaker; then dial number. To change back for normal handset use, press Speaker again.

To end call, press TALK.

Digital Clarity Power™ Technology

With Digital Clarity Power, high frequency sounds are amplified more than low frequency sounds so words are not just louder but clearer and easier to understand. It also provides intelligent amplification to make soft sounds audible, while keeping loud sounds bearable.

BOOST ON/OFF

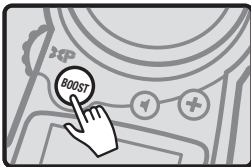

BOOST On/Off

The BOOST button controls the loudness of the receiver. Once the BOOST button is pressed, an extra level of amplification is added over the entire range of volume control.

TELEPHONE OPERATIONS

BASIC HANDSET OPERATIONS

Volume Control

During a call, the dial on the side controls the level of volume for the handset and speakerphone. The volume dial provides up to 16dB of volume before the BOOST button is activated. Once the BOOST button is pressed, the C4230 will provide up to 50dB of amplification.

When phone is not in use, the dial on the side controls the level of the ringer volume.

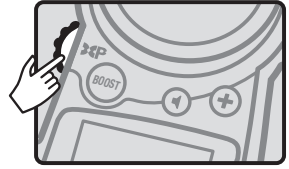

Boost Override

Select Boost Override on the Main Menu. Use the Arrow buttons to scroll from ON to OFF. Select your choice and then press the (soft key) Save.

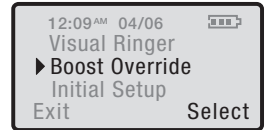

ON – When the Boost override is set to ON, the Boost function will be ON every time a call starts. If the phone hangs up, the Boost will remain ON.

OFF – When the Boost is set to OFF, the Boost function will be OFF. Every time a call starts, the user will need to press the BOOST button in order to gain the extra level of amplification. If the phone hangs up, the BOOST button will reset to OFF.

BOOST OVERRIDE (ON/OFF)

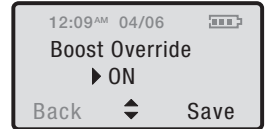

Audio Tone

Press the Tone button to change the style of amplification. Switching audio tones will change how the telephone conversation sounds to you. See the matrix on page 16 for general recommendations on audio tones based on your particular hearing situation.

ADJUSTING TONE

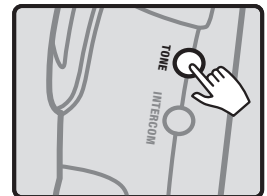

TELEPHONE OPERATIONS

General Recommendations for Tone Settings on the C4230™ Telephone*

	Audio Tone 1	Audio Tone 2	Audio Tone 3	Audio Tone 4
Amplification Type	Bass Low Frequency Amplification	Flat Frequency Amplification	Clarity Power	Multiband Compression- Low
Setting Emphasis	Power/Loudness	Power/Loudness	Power/Loudness	Speech Intelligibility
User listens while wearing Digital Hearing Aids		●	●	
User listens while wearing Analog Hearing Aids				●
User has difficulty understanding speech on telephone				●
User with Noise Induced Hearing Loss	●			
Mild to Moderate Hearing Loss	●			●
With some High Frequency Hearing Loss			●	
With significant High Frequency Hearing Loss				●
With Low Frequency Hearing Loss	●			
Moderate to Severe Hearing Loss		●	●	
With High Frequency Hearing Loss			●	●
With Low Frequency Hearing Loss	●			
With Loss across All Frequencies		●		

*Notes:

1. These are general recommendations. Hearing loss is specific to each individual; therefore, Clarity® recommends an end user tries all four setting to see which will work best for their particular hearing condition.
2. Boost must be on for audio tone settings to activate.
3. Noise reduction, acoustic echo cancellation and all other DCP™ features are active regardless of the tone setting.

TELEPHONE OPERATIONS

BASIC HANDSET OPERATIONS

Flash

The FLASH (CL/FL) button is activated to use custom calling services such as Call Waiting or Three Way Calling. Please contact your local telephone company for information on these services.

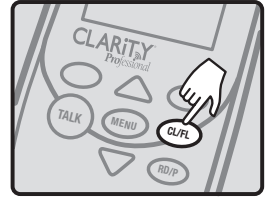

Last number dialed

Press RD/P to call last number dialed.

The last number dialed (up to 32 digits) is stored in the redial memory until another number is dialed.

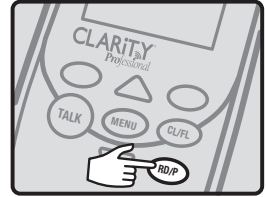

Intercom

Press the Intercom button to page base. To answer from the base, press the intercom button, then the Talk button. This will allow you to talk to the person on the handset.

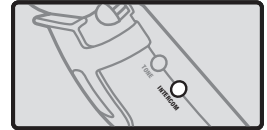

Pause Feature

Programming in a pause will cause the phone to wait two (2) seconds before dialing additional numbers. This feature may be used when it is necessary to dial an access code (9, for example). Wait for the second dial tone, and then dial the outgoing number. Press the RD/P button at the required point during the memory storage process to program a pause.

Mute and Hold

Press the (soft key) Mute on the handset and "Mute" will be displayed. This will turn the microphone off on the handset.



TELEPHONE OPERATIONS

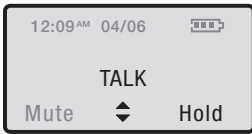

Press the (soft key) Hold on the menu to hold the line.

Press the (soft key) Unhold to return to the dialing screen and to your call.

Dialing (Tone/Pulse)

(See Page 25 for instructions)

BASIC BASE OPERATIONS

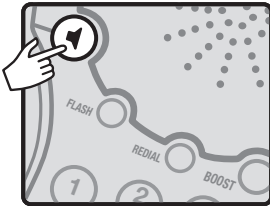

Making and answering calls

If you have call waiting service, press FLASH during a call to answer a second call. To make a call, press

◀ SPEAKERPHONE, then dial number. To end call, press ▶ SPEAKERPHONE again.

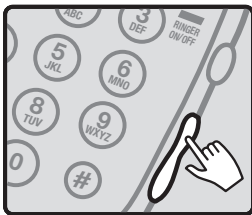

Volume Control

VOLUME UP and VOLUME DOWN buttons are used to adjust the volume of the ringer when SPEAKERPHONE is not in use.

When using the SPEAKERPHONE, VOLUME UP and VOLUME DOWN buttons are used to adjust the volume of the speaker.

When using the Answering Machine, VOLUME UP and VOLUME DOWN buttons are used to adjust the volume of the answering machine during message playback.

TELEPHONE OPERATIONS

Boost On/Off

The BOOST button controls the loudness of the SPEAKERPHONE. Once the BOOST button is pressed, an extra level of amplification is added over the entire range of volume control.

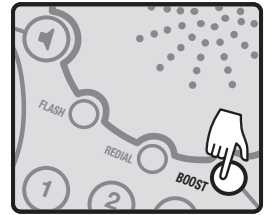

Last number redialed

Press REDIAL to dial last number dialed from the base.

The last number dialed (up to 32 digits) is stored in the redial memory until another number is dialed.

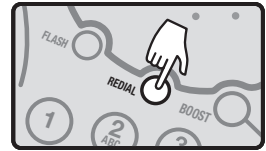

Flash

The FLASH button is activated to use custom calling services such as Call Waiting or Three Way Calling. Please contact your local telephone company for information on these services.

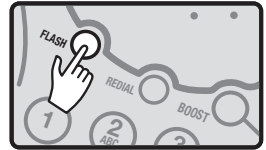

Mute

Press the MUTE button to turn the microphone off on the SPEAKERPHONE.

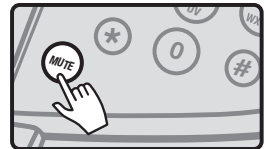

Page

Press PAGE button to page handset. To stop Paging, do one of the following:

1. Press the PAGE button again on the base.
2. Press the (soft key) EXIT on the handset.
3. Wait for 2 minutes until paging times out.

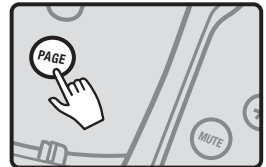

TELEPHONE OPERATIONS

INTERCOM AND PAGING

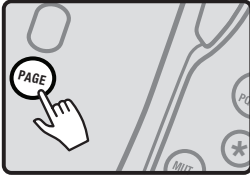

Intercom from Base

(The intercom will allow the person on the Handset to speak to the person at the Base station.)

Press the PAGE button on the base.

If additional handsets have been purchased, press the page button on the base and the handset number you wish to page on the base dial pad. To Page all handsets, press Page then 0.

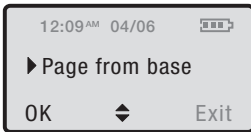

The screen on the handset will display “Page from Base.” Press the (soft key) OK. This will turn the intercom ON. To turn the intercom OFF, press the (soft key) EXIT on handset.



Ringer Style

The ringer style adjustments are located on the side of the telephone base. The style of ring can be adjusted by pressing the RING STYLE key. Six (6) styles are available allowing you to customize the ring on the base. To help choose a ring style, each ring tone will sound for two (2) seconds as the choices are scrolled through.

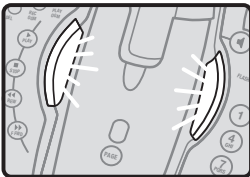

Visual Ringer

Visual ringers are located in the base. When an incoming call is received, these lights will flash.

TELEPHONE OPERATIONS

Lamp Flasher

This function is only available with the optional C2210 Lamp Flasher Notification Accessory. Instructions on use will come with purchase of Lamp Flasher. For more information on purchasing contact Clarity at 1-800-426-3738.

Bed Shaker

This function is only available with the optional C2210 Bed Shaker Notification Accessory. Instructions on use will come with purchase of Bed Shaker. For more information on purchasing contact Clarity at 1-800-426-3738.

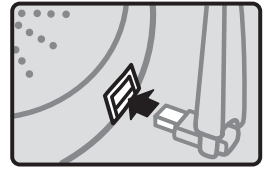

Note: This is not a USB port. Please see the C2210 Lamp Flasher instructions for installation.

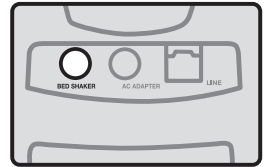

Note: Please see C2210 Bed Shaker instructions for installation.

OTHER FEATURES ON HANDSET

Ringer Setup

Use the Arrow buttons to scroll down the main menu to Ringer Setup. Press the (soft key) Select to choose Ringer Setup. Then choose from the submenu: Ringer Tone or Keypad Tones.

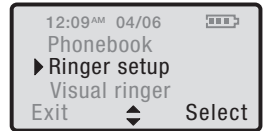

Ringer Tone: The default Ringer tone will be set to (Ring Tone 1). To change ring tone, select Ringer tone from the submenu. **Note:** There are six (6) Ring Tones to choose from.

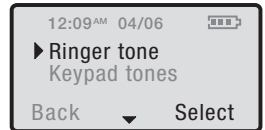

Use the Arrow buttons to scroll up and down to choose the ringer style. The ring styles will play as the selections are scrolled through. (The ringer Off/On switch must be On). Select the desired ring tone and then press the (soft key) Save. This will take you back to the submenu.

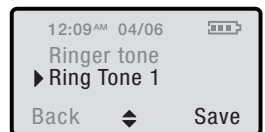

TELEPHONE OPERATIONS

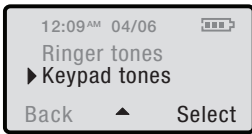

Keypad Tones: The Keypad Tones are defaulted to On. To turn the keypad tones Off, go to the Keypad tones, and press the (soft key) Select.

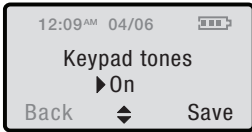

Use the Arrow buttons to scroll down to On or Off. Make your selection, and then press the (soft key) Save.

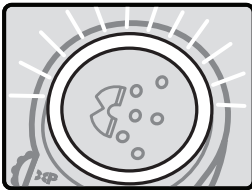

Visual Ringer

A Visual ringer is located in the handset. When an incoming call is received, the light will flash.

To turn off the Visual Ringer select Menu, scroll down to Visual Ringer and press Select. Next, scroll to Off and press the (soft key) Save.

The visual ringer will also blink when there are new messages on the answering machine.

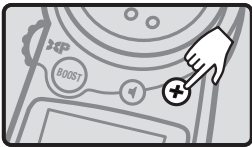

HELP Key / Memory Storage

The HELP Button can be programmed with up to 24 digits.

1. Press the HELP Button.
2. Dial the number you wish to store.
3. Press the HELP Button again.
4. A long beep will indicate the programming process is complete.

IMPORTANT: The HELP Button is **NOT** pre-programmed for 911. **We do not recommend programming 911 into your phone memory.**

To Place Call Using Help Key

Press the Help Button
(The phone will dial the preprogrammed number)

TELEPHONE OPERATIONS

Date and Time

Note: If you have Caller ID service the Date and Time will automatically set when you receive your first call. (Caller ID will not auto set Day of Week)

Select DATE AND TIME on the menu screen.

The screen will then display a time with the hour blinking.

Use the key pad to enter the desired time.

Four digits must be entered: (08:25). Press the (soft key) AM/PM to change from AM to PM.

Press the Arrow buttons down and Time format will appear on the screen. Use the (soft key) Change to select the desired time format: 12 hour clock or a 24 hour clock.

Press the Arrow button down again and choose Date format. Use the (soft key) Change to select DD/MM or MM/DD. (DD/MM stands for Date/Month and MM/DD stands for Month/Date.) Press the Arrow button down again to enter the Date. Four digits must be entered: (04/06).

SELECT DATE AND TIME

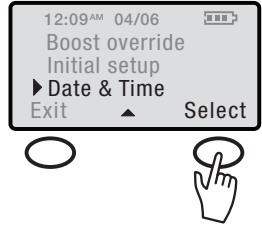

SET TIME

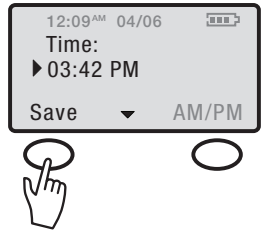

SELECT TIME FORMAT

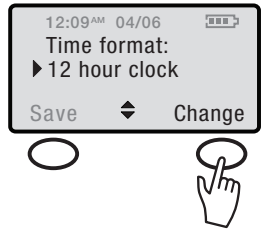

SELECT DATE FORMAT

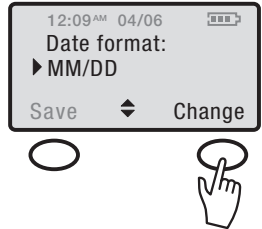

TELEPHONE OPERATIONS

SET MONTH AND DATE

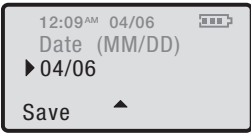

Once the date and time have been entered, press the (soft key) Save to save settings.



Press the Arrow button down again and choose the weekday. Use the (soft key) Change to select day of the week. Once the day of the week has been entered, press the (soft key) Save to save setting.

INITIAL SETUP

INITIAL SETUP



Select Initial Setup on the main menu. The sub menu will then display:

- Registration
- Auto Talk
- Answer Setup
- Language
- Dialing Mode
- LCD Contrast

INITIAL SETUP

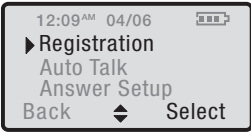

Registration

The handset that comes with the base will automatically be registered to the base. It will be named Handset 1. The C4230 will support up to 3 additional handsets. If any additional handsets are purchased, the registration instructions will come with the purchased handset. Contact Clarity Customer Service for information on purchasing additional handsets.

TELEPHONE OPERATIONS

Auto Talk

Auto Talk allows the user to remove the Handset from the base during an incoming call and immediately start talking without pressing the Talk Button.

Auto Talk's default is set to Off. When picking the handset off the base, press the Talk button to answer the phone.

For the handset to automatically answer after removing it from the base, set Auto Talk to ON.

Select Auto Talk on the submenu. Scroll to ON or OFF, select the preferred setting, and then press the (soft key) Save.

SETTING AUTO TALK



Telephone Answering Machine (Answer Setup)

(See page 33 for setup instructions.)

Dialing Mode

Tone or Pulse

Based on the type of telephone service you have, use tone for touch-tone service or pulse for rotary dialing.

Select Dialing Mode on the submenu. "Tone" or "Pulse" will then be displayed. The pointer will be pointed to the current setting.

SETUP DIALING MODE



Use the Arrow buttons to scroll between Tone and Pulse.

Press the (soft key) Save to save the setting and return to the Main Menu Screen.

Or

Press the * button and dial number to temporarily switch from pulse to tone.

SELECT DIALING MODE



TELEPHONE OPERATIONS

SET LCD CONTRAST



LCD Contrast

Select LCD Contrast on the submenu.

Use the Arrow buttons to scroll from Lo to Hi. Select the desired setting and then press the (soft key) Save. This will save the setting and return to the Main Menu Screen.

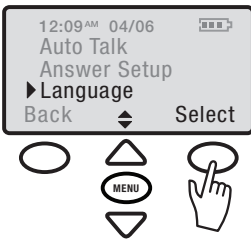

Language Menu

Select Initial setup on the main menu.



Use the Arrow buttons to scroll down and select language on the menu. Choices include English, French or Spanish. Make selection, and press the (soft key) Save. Press the MENU button to return to the main screen.

Handset Phonebook/Memory Storage

The C4230 will hold up to 40 names in the phonebook. The maximum characters for the name entry are 10. Up to 24 digits can be entered for the phone number.

Error tones and timeouts

If more than 10 characters for the name or 24 digits for the phone number are entered an error tone will sound and the character or number will not be accepted.

To enter a pause, dial the number, and press the pound # button twice or press the RD/P Button. This will enter a two (2) second pause.

TELEPHONE OPERATIONS

New Phone book entries

To enter names:

Select PhoneBook in the main menu.

Select "Add New Name" on the sub menu. "Name:" will be displayed on the screen. Type in the name using the dialing pad. If a mistake is made press the (soft key) Clear to clear the last letter. To add a space between names press the POUND (#) button.

EXAMPLE

ABC
2

- Press once to enter "A"
- Press twice to enter "B"
- Press 3 times to enter "C"
- Press 4 times to enter "2"



Next, press the Arrow button down to enter phone number.

To enter phone number:

After pressing the Arrow button down, "Number:" will be displayed on the screen.

Type in the number using the keypad. If a mistake is made press the (soft key) Clear to clear the last digit.

Press the (soft key) Save and the number and the name will be saved.

If the Names list is full while the user selects New Entry, the word "FULL" is displayed on the screen. Press Exit to return to the NAMES menu. If the Names memory is full, a new entry can be entered after the deletion of another entry.

SELECT PHONEBOOK

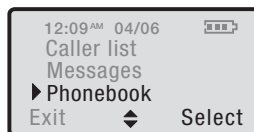

NEW PHONEBOOK ENTRY

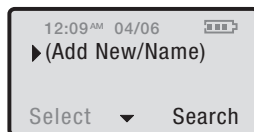

ADDING NAME TO PHONEBOOK

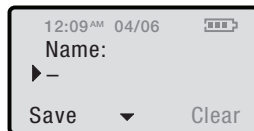

NEW PHONE NUMBER ENTRY

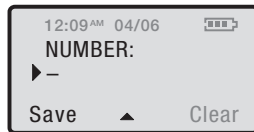

TELEPHONE OPERATIONS



To Edit or Erase Entries

Use the Arrow buttons to browse through the phonebook. Select the desired name to edit or delete, and press the (soft key) Option.



The screen will display Edit or Erase. Select Edit.

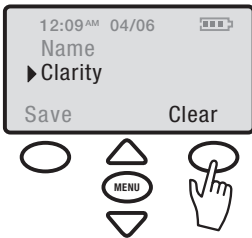

To edit name use the (soft key) Clear to clear the letters of the name. Retype in the changes then press the (soft key) Save to save the changes.

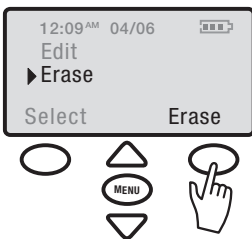

To Erase Name and Number select the (soft key) Erase. "Erase phonebk Entry" will appear.

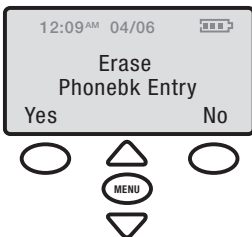

Choose Yes to erase entry or No to keep entry as is. After making a selection, the main phonebook menu will reappear on the screen.

TELEPHONE OPERATIONS

Saving Caller ID information into Phonebook

Select Caller List on the Main Menu. Then select the desired name to be stored into the phonebook.



Press the (soft key) Options. Then use the Arrow buttons to scroll down to Store.

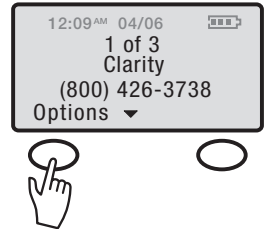

Press the (soft key) Select to store the name and number into the phonebook.



Phonebook Search

Select Phonebook on the main menu.

Use the Arrow buttons to scroll down the list of names stored in the phonebook. The list of names will be stored alphabetically.



Press the (soft key) View to view name and number. If there is no entry to select, "Empty List" will display.

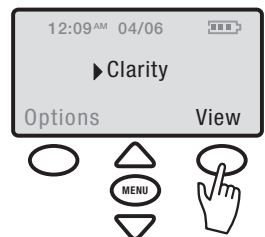

TELEPHONE OPERATIONS

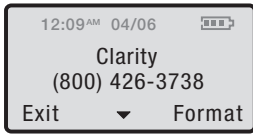

When viewing the phonebook entry, press the (soft key) Format to place the area code in parenthesis or add 1 in front of the area code.

To dial from phonebook

Select the desired name and number from the phonebook and press the TALK button. This will automatically dial the selected phonebook entry.

CALLER ID OPERATIONS

NOTE: This is a service that is provided through your local telephone company.

This telephone will automatically display the incoming caller's name and number along with the date and time of the call. It will record up to forty (40) calls and store the data into memory.

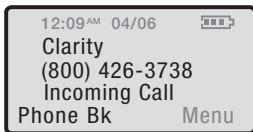

Incoming Call

"Incoming Call" will blink on the handset display when a new call is received. The first row on the display will have the caller's ID. If there is no information, the row will be blank. The second row displays the incoming telephone number. If the number is longer than 12 digits, the LCD will toggle the displayed number between the first 12 digits and the remaining digits.

Receiving Call Waiting Caller ID

When you are on an existing call, a tone will emit, and the caller ID will display the incoming caller's information.

If the 2nd incoming call is not accessed, the Caller ID information will be transferred into the Caller log. This caller information is considered "old".

TELEPHONE OPERATIONS

Caller ID Review

If there is new call information, the display will show the number of new calls received before they have been reviewed.

Select Caller List from the main menu. Use Arrow buttons to scroll up or down to view the Caller ID content. The first row of the display indicates the sequence of calls received. Press the Arrow button down to scroll through the Caller ID information from the most recent record to the oldest.



No calls

If the Caller ID list is empty, the display will show "No Calls."



Unknown call

If a call is from another country or the caller's number is not available, UNKNOWN is displayed and stored in the Caller ID log.

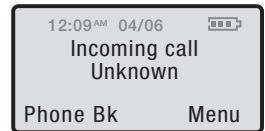

Block Call

If the number is blocked or withheld, PRIVATE is displayed and stored in Caller ID log.

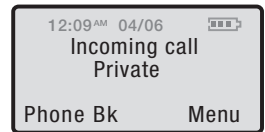

Callback From Caller ID Information

The desired CID record should be selected from the CID list. Press TALK once. The unit will automatically go off-hook and dial the selected number.

TELEPHONE OPERATIONS

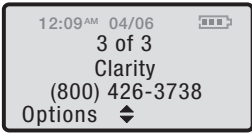

Erasing Caller ID Information

Select the desired CID record you would like to delete. Next, press the (soft key) Options.

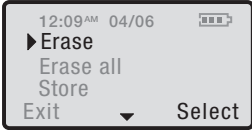

Choose erase on the sub-menu, and then press the (soft key) Select.

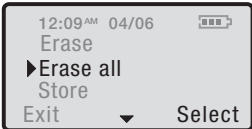

To erase all entries, scroll down to Erase All.

Press the (soft key) Select.

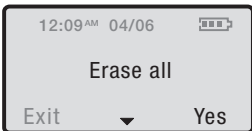

The screen will display “Erase All”. Press the (soft key) Yes.

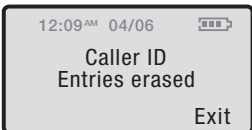

The screen will then display “Caller ID Entries Erased.”

TELEPHONE OPERATIONS

BASIC BASE FUNCTIONS

ANSWERING MACHINE

Message Capacity

The answering machine will hold up to 10 minutes of messages.

The Telephone Answering Machine can be accessed in the following three ways:

- Access from the Base
- Access from the Handset
- Access from a remote location.

ACCESS ANSWERING MACHINE FUNCTIONS FROM BASE

On/Off

Press the ON/OFF button on the base to turn the answering machine ON or OFF.

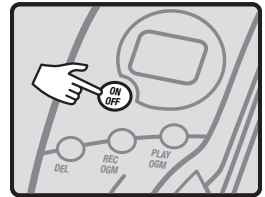

Rew (Rewind)

Press the REW (Rewind) button to rewind the message being played.

Press REW multiple times to go to the previous messages.

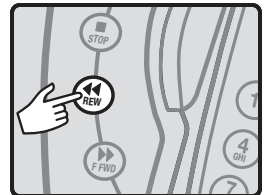

Stop

Press the STOP button to stop the Message being played.

TELEPHONE OPERATIONS

FFWD

Press the FFWD (Forward) button to forward to the next message.

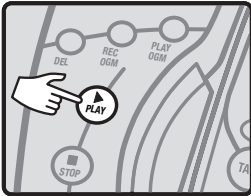

Play

Press the PLAY button to play the messages received.

When playback begins, the number of new messages received will be announced, as well as the day and time message was recorded.

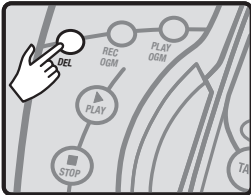

Delete

Press the DELETE button to delete the message being played back on the answering machine.

Press and hold the DELETE button when a message is playing until the number of messages begins to blink. After the number of messages begins blinking, press the DELETE button again. This will Delete all messages.

OGM Rec (Outgoing Message)

(The outgoing message will be the message a caller hears when the answering machine answers the call.)

Note: The answering machine comes with a pre-recorded message that can be used.

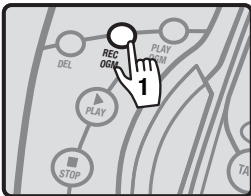

Press the REC OGM button (1) release and record your own personal outgoing message, press the REC OGM button again to stop your recording. Your message will automatically play back to you. If you do not like your message, record your message again.

See page 36 for additional OGM Options.



OGM Play (Outgoing Message)

Press the PLAY OGM button (2) to play the outgoing message.

TELEPHONE OPERATIONS

LED Screen

The screen will display the number of messages received on the answering machine.

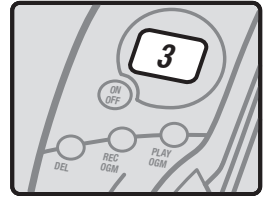

Access Answering Machine functions from Handset

Select Messages from the Main Menu screen. The sub menu will then be displayed. Press the number key on the handset or press the (soft-key) Select on the menu to activate each of the following functions.

- 1: Review
- 2: Play/Stop
- 3: Skip
- 4: Answer On/Off
- 5: Memo
- 6: Repeat Menu
- 0: Erase

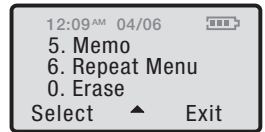
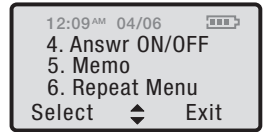
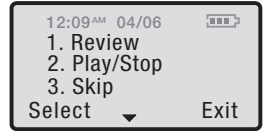
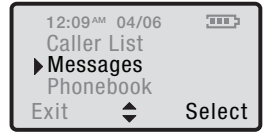

TELEPHONE OPERATIONS

OTHER HANDSET OPTIONS FOR ANSWERING MACHINE

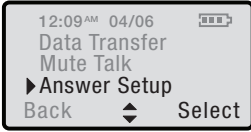

The options below can be accessed by going to the Main Menu and selecting Initial Setup. Use the Arrow keys to scroll to Answer Setup, and press the (soft-key) Select.

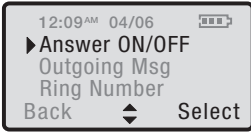

Answer On/Off

To turn Answering Machine ON/OFF from the handset. Select Answer ON/OFF. Then Save your choice.

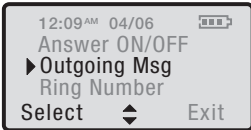

Outgoing Messages

Select Outgoing Msg. Choose one of the following options: Play OGM, Record OGM, Change OGM, or Erase OGM.

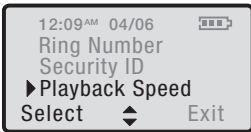

Slowdown Message Playback Speed

Select Playback Speed from the submenu. Then, scroll and select the desired speed to playback messages.

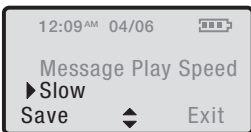

Choose one of the following: Normal, Slow, or Slowest and press the (soft key) Save.

TELEPHONE OPERATIONS

Play OGM

Press the (soft key) Select to play outgoing message.



Record OGM

Use the Arrow button to scroll to Record OGM and the press the (soft key) Select.

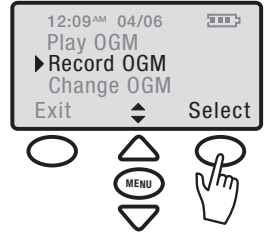

A new screen will appear. Select Yes to record outgoing message or No to return to previous menu.

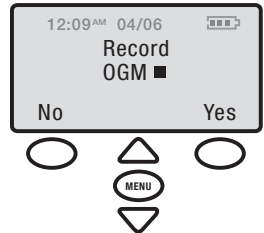

Change OGM

Use the Arrow button to scroll to Change OGM and press the (soft key) Select.

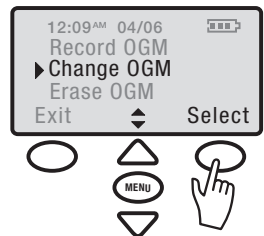

A new screen will appear. Then select Recorded OGM or Default OGM (the prerecorded message).



TELEPHONE OPERATIONS

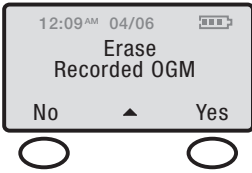

Erase OGM

Use the Arrow button to scroll to Erase OGM. A new screen will appear. Select Yes or No to Erase.



Ring Number

Select Ringer Number.



Scroll up or down to select the desired number of rings to have before the Answering Machine answers.

Note: The options are 3-6 rings or toll saver.

Toll Saver

Toll Saver is for remote access.

If you call your phone from a remote location and your answering machine picks up on the second ring, you have a new message. If your answering machine picks up after three (3) or more rings, you do not have a new message.

See page 40 for more Remote Access Options.

TELEPHONE OPERATIONS

Security ID

The Security ID is to access the Answering Machine from a Remote Location. The ID is defaulted as 1 2 3.

To change the Security ID, select Security ID and enter the three (3) digit code you wish to set as your new Security ID number.

- First select Initial Setup on the main menu.

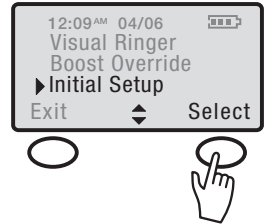

- Select Answer Setup.

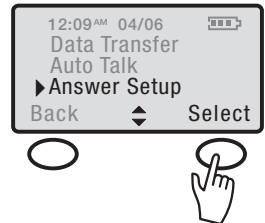

- Select Security ID.



- Enter the three (3) digit code you wish to set as your new Security ID number.



TELEPHONE OPERATIONS

Access from a Remote Location

The answering machine can be accessed from any touch-tone telephone by entering the three (3) digit security code after hearing the outgoing message.

Access Procedure:

1. Dial your phone number
2. Wait for the Answering Machine to pick up and issue the tone. Enter the security code. The DEFAULT CODE is 1 2 3. (The security code can be changed by the user. See section Security ID on page 39)
3. The menu will announce the following:
Press Two to Play Messages, Press Two again to Stop
Press Zero while playing a Message to Erase
Press One to Review
Press Three to Skip
Press Four to Turn OFF/ON
Press Seven to Review Menu Again

Bypass the Outgoing Message

Press any number after the announcement starts. The outgoing message will be bypassed, and a tone will be heard. The caller will be able to leave a message or enter the security code.

Remote ON while Answering Machine is OFF

If the Answering Machine is OFF, it will automatically answer on the 10th ring and announces "TAM off." Wait 7 seconds to enter the security ID.

The answering machine can be turned ON by pressing key four (4) after the security code is entered.

TELEPHONE OPERATIONS

Memory is full

If the answering machine memory is full, the answering machine will answer on the 10th ring and announce “Memory Full.” Wait seven (7) seconds to enter the security code.

Recording and playing memos

Memos are self-recorded messages. For example, a reminder to yourself or a message for someone else in your household. The memos can be saved, played back and deleted like incoming messages.

Recording Memos

Select Memo from the Message Menu.

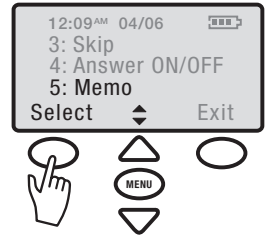

It will automatically start recording. After a memo is recorded, press the (soft key) End. This will save the memo.

The TALK button will then flash displaying a new MEMO (message).

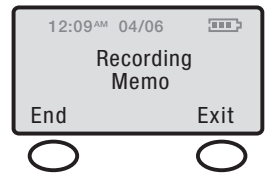

Note: Memos reduce the overall recording time available on the answering machine.

TROUBLESHOOTING

The unit will not operate / no dial tone:

- Verify the AC Adapter is securely plugged into AC outlet, the base and the telephone.
- Verify the telephone line cord is securely plugged into the wall jack and the telephone.
- Make sure the battery has been placed in the battery compartment correctly. (The circular metal contacts on battery need to touch the metal springs inside battery compartment.)
- Make sure the handset battery is fully charged.
- Verify the telephone is in the correct dialing mode tone (touch) or pulse (rotary).
- Make sure you are in the usable range of the base station.

The phone does not ring when you receive a call:

- Make sure the RINGER switch on the handset and base are set to ON.
- Verify the AC Adapter is securely plugged into the AC outlet, the base and the telephone.
- Verify the telephone line cord is securely plugged into the wall jack and the telephone.
- Make sure you are within the usable range of the base station.
- You may have too many extensions on your line. Try unplugging a few devices.

Noise, Static, Interference or Other Calls Heard while Using the Handset:

- Make sure you are within the usable range of the base station.
- Make sure the handset battery is fully charged.
- Try relocating the base unit to another location.
- Make sure the AC Adapter is not plugged into the wall outlet with other appliances.

TROUBLESHOOTING

Phone Will Not Hold Charge:

- Make sure the charging contacts on the handset and base are free of dust and dirt. While unplugged, clean the contacts with a soft cloth.
- Make sure CHARGE LED on the base is lit when the handset is in the cradle.
- Handset battery may have developed a memory, due to user improperly charging, and may need to be replaced. (Battery must be charged a full 12 hours before the first use.)

Difficulty in Placing or Receiving Calls:

- Move closer to the base and try again.
- Make sure you have selected the correct dialing mode, tone or pulse.
- Make sure the AC Adapter is not plugged into a wall outlet with other appliances. Disconnect for 5-10 seconds then reconnect. Place the handset back on the base and reinsert the AC Adapter.
- Make sure the handset battery is fully charged.

Your handset screen is showing Out of Range

- Move closer to the base.
- Handset may need to be re-registered to base.
- Place the handset into the base until the screen displays: "Handset Registered." It will take approximately 5-10 seconds for the handset to register to the base.

TECHNICAL SPECIFICATIONS

General

Model Number: C4230
Frequency: 5.8 GHz
Amplification: 50 dB

Handset Unit

Product in Inches: (L x W x H): 7.25 x 2 x 1.25
Weight in Pounds: 0.5 lb.

Base

Product in Inches: (L x W x H): 7 x 7 .75 x 4.75
Weight in Pounds: 1.0 lb.
Power Supply: AC Adaptor (120V AC, 60 Hz)

Handset and Base

Product in Inches: (L x W x H): 7.80 x 5.25 x 5.75
Weight in Pounds: 1.50 lbs.

Additional Handsets

Clarity Part number: C4230 HS
The C4230 will support a total of three (3) additional handsets.
(Additional Handsets sold separately.)

Battery Information

Battery Type: Ni-MH AAA 800 mAh 3.6V
Battery Life Talk Time: 3-4 Hours
Battery Life Standby: 6 days
Battery Backup: alkaline batteries, AA type
4 batteries, not rechargeable

Contact Clarity customer service for information on purchasing additional handsets or replacement battery.

Clarity Contact information:

Customer Service: 1-800-426-3738
Address: 4289 Bonny Oaks Drive,
Suite 106
Chattanooga, TN 37406

REGULATORY COMPLIANCE

Part 68 of FCC Rules Information

a) This equipment complies with Part 68 of the FCC rules and the requirements adopted by the ACTA. On the bottom of this equipment is a label that contains, among other information, a product identifier in the format US: AAAEQ##TXXXX. If requested, this number must be provided to the telephone company.

b) A plug and jack used to connect this equipment to the premises wiring and telephone network must comply with the applicable FCC Part 68 rules and requirements adopted by the ACTA. A compliant telephone cord and modular plug, RJ11 C USOC, is provided with this product. It is designed to be connected to a compatible modular jack that is also compliant. See installation instructions for details.

c) The REN is used to determine the number of devices that may be connected to a telephone line. Excessive RENs on a telephone line may result in the devices not ringing in response to an incoming call. In most but not all areas, the sum of RENs should not exceed five (5.0). To be certain of the number of devices that may be connected to a line, as determined by the total RENs, contact the local telephone company. For products approved after July 23, 2001, the REN for this product is part of the product identifier that has the format US:AAAEQ##TXXXX.

The digits represented by ## are the REN without a decimal point (e.g., 03 is a REN of 0.3). For earlier products, the REN is separately shown on the label.

d) If this telephone equipment causes harm to the telephone network, the telephone company will notify you in advance that temporary discontinuance of service may be required. But if advance notice isn't practical, the telephone company will notify the customer as soon as possible. Also, you will be advised of your right to file a complaint with the FCC if you believe it is necessary.

e) The telephone company may make changes in its facilities, equipment, operations or procedures that could affect the operation of the equipment. If this happens the telephone company will provide advance notice in order for you to make necessary modifications to maintain uninterrupted service.

f) If trouble is experienced with this telephone equipment, for repair or warranty information, please contact Clarity, 1-800-552-3368. If the equipment is causing harm to the telephone network, the telephone company may request that you disconnect the equipment until the problem is resolved.

g) This telephone equipment is not intended to be repaired and it contains no repairable parts. Opening the equipment or any attempt to perform repairs will void the warranty. For service or repairs, call 1-800-552-3368.

h) Connection to party line service is subject to state tariffs. Contact the state public utility commission, public service commission or corporation commission for information.

REGULATORY COMPLIANCE

i) If your home has specially wired alarm equipment connected to the telephone line, ensure the installation of this telephone equipment does not disable your alarm equipment. If you have questions about what will disable alarm equipment, consult your telephone company or a qualified installer.

j) This telephone equipment is hearing aid compatible.

Customer-Owned Coin/Credit Card Phones:

To comply with state tariffs, the telephone company must be given notification prior to connection. In some states, the state public utility commission, public service commission or corporation commission must give prior approval of connection.

Part 15 of FCC Rules Information

This device complies with Part 15 of the FCC Rules. Operation is subject to the following two conditions: (1) This device may not cause harmful interference, and (2) this device must accept any interference received, including interference that may cause undesired operation.

Your equipment has been tested and found to comply with the limits of a Class B digital device, pursuant to Part 15 of FCC rules. These limits are designed to provide reasonable protection against harmful interference in residential installation.

This equipment generates, uses and can radiate radio frequency energy and, if not installed and used in accordance with the instructions, may cause harmful interference to radio communications. However, there is no guarantee that interference will not occur in a particular installation; if this equipment does cause harmful interference to radio or television reception, which can be determined by turning the equipment off and on, you are encouraged to try to correct the interference by one of the following measures:

1. Where it can be done safely, reorient the receiving television or radio antenna.
2. To the extent possible, relocate the television, radio or other receiver with respect to the telephone equipment. (This increases the separation between the telephone equipment and the receiver.)
3. Connect the telephone equipment into an outlet on a circuit different from that to which the television, radio, or other receiver is connected.
4. Consult the dealer or an experienced Radio/TV Technician for help.

CAUTION: Changes or modifications **to this equipment** not expressly approved **by the party responsible** for compliance could void the user's authority to operate the equipment.

REGULATORY COMPLIANCE

Privacy of communications may not be ensured when using this phone.

CAUTION: To maintain the compliance with the FCC's RF exposure guideline, place the base unit at least 20 cm from nearby persons.

For body worn operation, this handset has been tested and meets the FCC RF exposure guidelines when used with the **(Plantronics)** accessories supplied or designated for this product. Use of other accessories may not ensure compliance with FCC RF exposure guidelines.

Industry Canada Technical Specifications

This product meets the applicable Industry Canada technical specifications.

Before installing this equipment, users should ensure that it is permissible to be connected to the facilities of the local telecommunications company. The equipment must also be installed using an acceptable method of connection. In some cases, the company's inside wiring associated with a single line individual service may be extended by means of a certified connector assembly (telephone extension cord). The customer should be aware that compliance with the above conditions may not prevent degradation of service in some situations. Repairs to certified equipment should be made by an authorized Canadian maintenance facility designated by the supplier.

Any repairs or alterations made by the user to this equipment, or equipment malfunctions, may give the telecommunications company cause to request the user to disconnect the equipment.

Users should ensure for their own protection that the electrical ground connections of the power utility, telephone lines and internal metallic water pipe system, if present, are connected together. This precaution may be particularly important in rural areas.

CAUTION: Users should not attempt to make such connections themselves, but should contact the appropriate electrical inspection authority, or electrician, as appropriate.

The Ringer Equivalence Number is an indication of the maximum number of terminals allowed to be connected to a telephone interface. The termination on an interface may consist of any combination of devices subject only to the requirement that the sum of the Ringer Equivalence Numbers of all the devices does not exceed five.

(The term "IC:" before the certification/registration number only signifies that the Industry Canada technical specifications were met.)

This Class B digital apparatus complies with Canadian ICES-003.

The party responsible for regulatory compliance:

Clarity, A Division of Plantronics, Inc.
4289 Bonny Oaks Drive, Suite 106
Chattanooga, TN 37406
Phone: 1-800-552-3368

WARRANTY & SERVICE

The following warranty and service information applies only to products purchased and used in the U.S. and Canada. For warranty information in other countries, please contact your local retailer or distributor.

Limited Warranty

Clarity, a division of Plantronics, Inc. (“Clarity”) warrants to the original consumer purchaser that, except for limitations and exclusions set forth below, this product shall be free from defects in materials and workmanship for a period of one (1) year from the date of original purchase (“Warranty Period”). The obligation of Clarity under this warranty shall be at Clarity’s option, without charge, of any part or unit that proves to be defective in material or workmanship during the Warranty Period.

Exclusions from Warranty

This warranty applies only to defects in factory materials and factory workmanship. Any condition caused by accident, abuse, misuse or improper operation, violation of instructions furnished by Clarity, destruction or alteration, improper electrical voltages or currents, or repair or maintenance attempted by anyone other than Clarity or an authorized service center, is not a defect covered by this warranty. Telephone

companies manufacture different types of equipment and Clarity does not warrant that its equipment is compatible with the equipment of a particular phone company.

Implied Warranties

Under state law, you may be entitled to the benefit of certain implied warranties. These implied warranties will continue in force only during the warranty period. Some states do allow limitations on how long an implied warranty lasts, so the above limitation may not apply to you.

Incidental or Consequential Damages

Neither Clarity nor your retail dealer or selling distributors has any responsibility for any incidental or consequential damages including without limitation, commercial loss or profit, or for any incidental expenses, expenses, loss of time, or inconvenience. Some states do not allow exclusion or limitation of incidental or consequential damage, so the above limitation or exclusion may not apply to you.

Other Legal Rights

This warranty gives you specific legal rights and you may also have other rights which vary from state to state.

WARRANTY & SERVICE

How to Obtain Warranty Service

To obtain warranty service, please prepay shipment and return the unit to the appropriate facility listed below.

In the United States

Clarity Service Center
4289 Bonny Oaks Drive, Suite 106
Chattanooga, Tennessee 37406

Tel: (423) 622-7793 or
(800) 426-3738
Fax: (423) 622-7646 or
(800) 325-8871

In Canada

Plantronics Service Center
8112 Trans-Canada Hwy.
Ville St. Laurent. Que.
Canada H4S 1M5

Tel: (800) 540-8363
(514) 956-8363
Fax: (514) 956-1825

Please use the original container, or pack the unit(s) in a sturdy carton with sufficient packing material to prevent damage.

Include the following information:

1. A proof-of-purchase indicating model number and date of purchase.
2. Bill-to address.
3. Ship-to address.
4. Number and description of units shipped.
5. Name and telephone number of person to call, should contact be necessary.
6. Reason for return and description of the problem.

Damage occurring during shipment is deemed the responsibility of the carrier, and claims should be made directly with the carrier.